

Features

Easy Integration to host system
Small Footprint 1.00" x 2.5"
Full silicon-based design
Full Duplex 2400bps
Low Power Consumption and Sleep Mode
Global option available
V.24 DTE Interface
3.3V Operation
5kV surge 10 X 700usec surge compliance
Data Speeds:
V.22bis – 2400bps
V.22, Bell 212 – 1200bps
V.21, Bell 103 – 300bps
V.23-1200/75bps (w/turnaround (PAVI))
Bell 202 – 1200bps
Dynamic Range –9dBm to –43dBm
Caller ID and Ring detect Capability

Applications

Vending/Gaming Machines
Remote Monitoring
Set Top Box Billing Modem
Direct Broadcast Satellite
Utility Meters
Remote Telemetry
POS Terminals
Embedded Applications
Remote Diagnostics

Approvals

TIA/EIA 968 (FCC part 68)
UL60950
EN60950
IEC60950
EN55022B
UL1950
EN55024
TBR-21
CISPR22B

Description

The CPW2424 is an all silicon, low profile, V.22bis 2400bps embedded modem module intended for applications that require a data communications link to the Public Switched Telephone Network (PSTN). The module form factor is a 1.00" x 2.5" printed circuit board that can be inserted into a socket or soldered into the host system mother board. The CPW2424 can be used for a variety of different applications such as a set top box billing modem or any remote data acquisition application.

The modem module can be customized for various features such as global, fully programmable AC phone line terminations, parallel phone detect and power cross protection. The module can also be optimized for low cost, region specific, basic modem operation that are common in consumer applications. The CPW2424 supports a standard V.24 interface to the host DTE.

Ordering Information

Part Number: CPW2424- x - x
AC Termination ←
Additional Options ←

AC Termination

N : 600ohm AC impedance Basic Modem
E : TBR21 AC impedance Basic Modem
W : Contact WTC for country specific impedance
P : Programmable AC Termination

Additional Options (add letter codes)

A : Parallel Phone Detect
B : Another Phone Off-Hook and Power Cross Protection
C : Dummy ringer (required for specific countries)
D : Host Programmable DC Termination

Absolute Maximum Ratings (@ 25 °C)

Parameter	Min	Max	Units
Isolation Voltage	-	3000	Vrms
Tip/Ring Current	8	130	mA
Operating Temperature	0	+50	°C
Storage Temperature	-55	150	°C
Relative Humidity(Non-Condensing)	10	85	%
Soldering Temperature	-	260	°C

Absolute Maximum Ratings are stress ratings. Stresses in excess of these ratings can cause permanent damage to device. Functional operation of the device at these or any other conditions beyond those indicated in the operation sections of this data sheet is not implied. Exposure of the device to the absolute maximum ratings for an extended period may degrade the device and effect it reliability.

Electrical Characteristics

Parameter	Conditions	Min	Typ	Max	Unit
DC Electrical Characteristics @ 25 °C					
Vcc Supply Voltage					
Vcc Supply Current – Idle(Sleep Mode)	Vcc=3.3V	3.1	3.3	3.4	V
Vcc Supply Current – Active	Vcc=3.3V	-	5	10	mA
Line Matching Impedance	Vcc=3.3V	-	70	100	mA
Rating Voltage	Vcc=3.3V, f=20Hz	-	600	-	Ω
Ringer Equivalence Number (REN)	Vcc=3.3V	-	2.2	30	V _{RMS}
Telephone Line Loop Current	Vcc=3.3V	-	0.6B	-	-
	Vcc=3.3V	20	-	120	mA
DTE DC Characteristics @ 25 °C					
Input High Voltage VIH		2	-	5.3	
Input Low Voltage VIL	GND<Vo<Vcc	0	-	0.8	
Input Leakage Current IL	IOH=-2.0mA;	-10	-	10	
Output High Voltage VOH	Vcc=5V	4.0	-	-	
Output Low Voltage VOL	IOI=+2.0mA; Vcc=5V	0	-	0.4	
Input High Voltage VIH	Vcc=5V	0.7	2.6	5.3	
Input Low Voltage VIL	Vcc=5V	GND-0.3	1.6	0.2Vcc	

Pinout

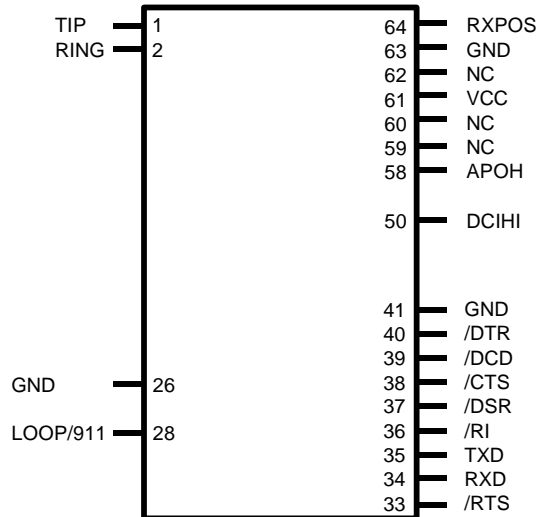

Definitions

Pin	I/O	Name	Function
1	IF	TIP	Tip connection to telephone line
2	IF	RING	Ring connection to telephone line
26	GND	GND	Power supply return
28	O	LOOP/911	Loop current detector output
33	I	RTS	Request To Send (TTL Active Low)
34	O	RXD	Serial data input from host DTE (TTL Active Low)
35	I	TXD	Serial data output to host DTE (TTL Active Low)
36	O	/RI	Ring Indicate (TTL Active Low)
37	O	/DSR	Data Set Ready (TTL Active Low)
38	O	/CTS	Clear To Send(TTL Active Low)
39	O	/DCD	Data Carrier Detect (TTL Active Low)
40	I	/DTR	Data Terminal Ready (TTL Active Low)
41	GND	GND	Ground. Connected to Ground on the interface circuit.
50	I	DCIHI	DC Terminal Control
58	I	APOH	Another Phone Off-Hook
61	PWR	VCC	Connects to external host power source of +3.3V +/-5%
63	GND	GND	Power supply return
64	O	RXPOS	RX Positive

Modem Module Build Options

The design will accommodate build options that will allow various features ranging from a fully programmable global modem to a low cost, region specific, basic modem. All of the build options will include the basic V.22bis modem circuit that includes the 2901CL and CPC5621 components offering the lowest cost bill-of-materials (option A). These options are identified below:

Basic Modem Option (A)

This configuration is optimized for a reduced bill-of-materials and overall cost. AC and DC terminations are preset for the specific country of deployment in order to meet homologation requirements.

Programmable AC Termination Option (B)

A host-side mux circuit option is available for global applications sets the phone line AC termination impedance. The current board has stuffing options per the table below. Please contact WTC for other AC termination options

Parallel Phone Detect Option (C)

Some applications require the need to detect another phone or a parallel phone going off-hook on the same phone line after the CPW2424 modem has gone off-hook. This allows the host processor interfacing with the CPW2424 the ability to hang-up so that the parallel phone user may make their phone call.

Another Phone Off-Hook and Power Cross Protection Option (D)

Some applications require the need to detect if another phone is off-hook or line-in-use is occurring before the CPW2424 modem goes off-hook. The modem device can retry the phone line at another time when it is not being used

PTC Option (E)

A PTC may be used at the input of the tip from the phone line to protect the modem from dangerous power cross and surge voltages.

Dummy Ringer Option (F)

Some countries require the presence of a dummy ringer circuit that establishes a load impedance. These countries are listed below.

Host Programmable DC Termination Option (G)

Certain European applications may need to adhere to the TBR-21 specification which specifies the maximum phone line current to 60mA instead of the 130mA limit in North America and Asia.

CPW2424 Embedded Modem Module

V.22bis Global Socket Modem With Integrated Silicon DAA

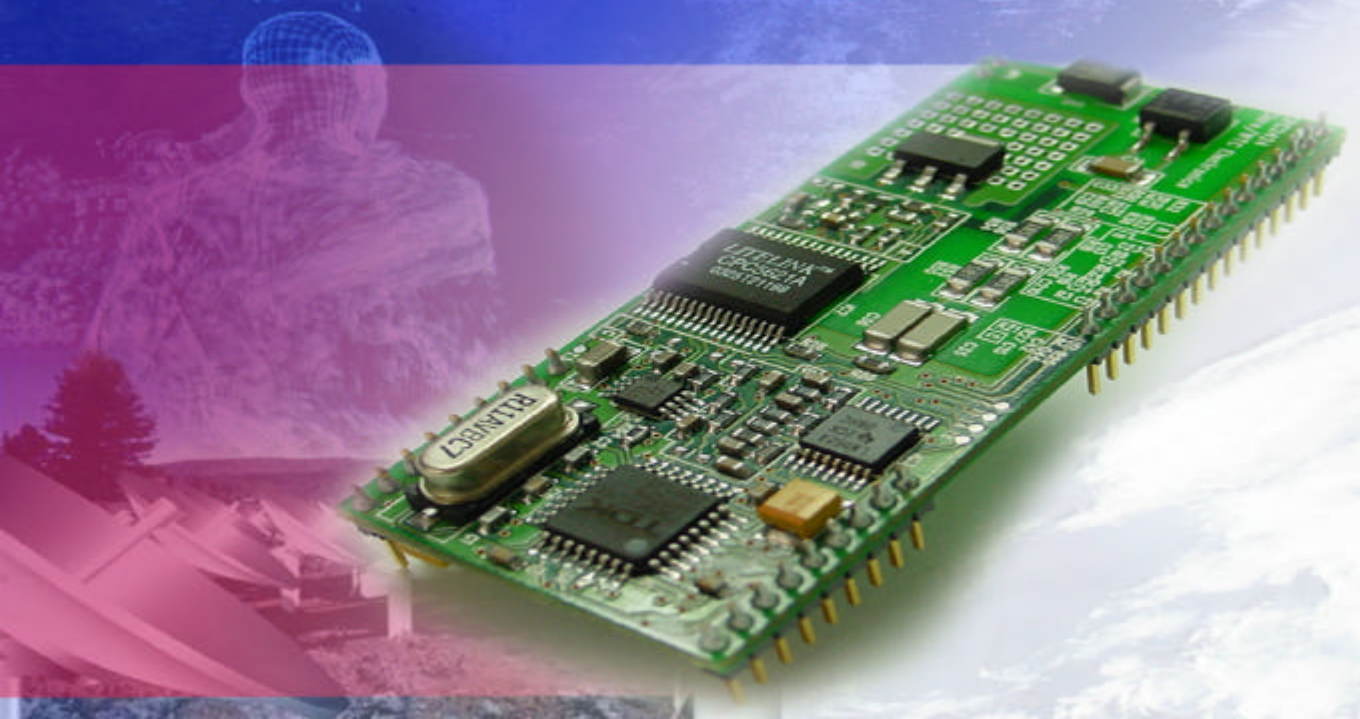

Product Description

The CPW2424 is an all silicon, low profile, V.22bis 2400bps embedded modem module intended for applications that require a data communications link to the Public Switched Telephone Network (PSTN). The module form factor is a 1.00" x 2.5" printed circuit board that can be inserted into a socket or soldered into the host system mother board. The CPW2424 can be used for a variety of different applications such as a set top box billing modem, point-of-sales terminal or any remote data acquisition application.

The modem module can be customized for various features such as global, fully programmable AC phone line terminations, parallel phone detect and power cross protection. The module can also be optimized for low cost, region specific, basic modem operation that is common in consumer applications. The CPW2424 supports a standard V.24 interface to the host DTE.

CPW2424 Physical Dimension

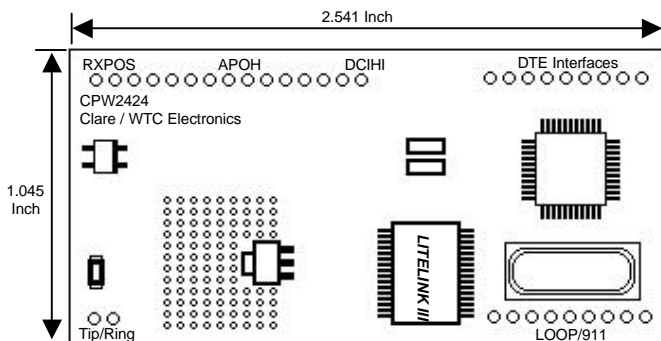

Product Brief

THE CPW2424 WITH THE CLARE LITELINK III SILICON DAA OFFERS GLOBAL COMPLIANCE NEEDED IN A SINGLE FOOTPRINT AND THE MOST ROBUST DESIGN IN THE WORLD.



CPW2424 Embedded Modem Module

V.22bis Global Socket Modem with integrated silicon DAA

Features

- Easy Integration to host system
- Small Footprint 1.00" x 2.5"
- Full silicon-based design
- Full Duplex 2400bps
- DTMF generation and detection
- On-chip datapump and controller
- AT command set
- Integrated DAA
- Low Power Consumption and Sleep Mode
- Security modem formats
- Global option available
- V.24 DTE Interface
- 3.3V Operation
- 6kV surge 10 X 700usec surge compliance
- Data Speeds:
 - V.22bis – 2400bps
 - V.22, Bell 212 – 1200bps
 - V.21, Bell 103 – 300bps
 - V.23-1200/75bps (w/turnaround (PAVI))
 - Bell 202 – 1200bps
- Dynamic Range –9dBm to –43dBm
- Caller ID and Ring detect Capability

Approvals

TIA/EIA 968 (FCC part 68)
UL60950
EN60950
IEC60950
EN55022B
UL1950
EN55024
TBR-21
CISPR22B

Applications

- Set Top Box Machines
- POS Terminals
- Vending/Gaming Machine
- Direct Broadcast Satellite
- Utility Meters
- Embedded Applications
- Remote Telemetry
- Remote Monitoring
- Remote Diagnostics



Ratings (@25°C)

Parameter	Min	Max	Units
Isolation Voltage	---	3000	Vrms
Tip/Ring Current	8	130	mA
Operating Temperature	0	+50	°C
Storage Temperature (Non-Condensing)	-55	150	°C
Soldering Temperature	---	260	°C

Custom Modifications

WTC provides custom modifications and manufacturing for large unit volume board opportunities. We are equipped to expedite both design and manufacture requirements of various custom board programs.

Global DAA Technology

Clare's LITELINK III single-chip Silicon phone line interfaces (DAA) use optical technology to include the required isolation barrier in the package, eliminating high cost discrete components, capacitors, and transformers. This solution saves cost relative to competitive solutions through reduced passive component count and smaller printed-circuit board space.

Ordering Information

Part Number: **CPW2424- x - x**

AC Termination ←
Additional Options ←

AC Termination

- N** : 600ohm AC impedance Basic Modem
- E** : TBR21 AC impedance Basic Modem
- W** : Contact WTC for country specific impedance
- P** : Programmable AC Termination

Additional Options (add letter codes)

- A** : Parallel Phone Detect
- B** : Another Phone Off-Hook and Power Cross Protection
- C** : Dummy ringer (required for specific countries)
- D** : Host Programmable DC Termination

Contact Information

WTC Electronics, Inc.

3731 Wilshire Blvd. Suite 506, Los Angeles, CA90010.

Tel: 1(213)380-7555 Fax: 1(213)380-1736

Email: sales@wtcelectronics.com

Web site: <http://www.wtcelectronics.com>

